

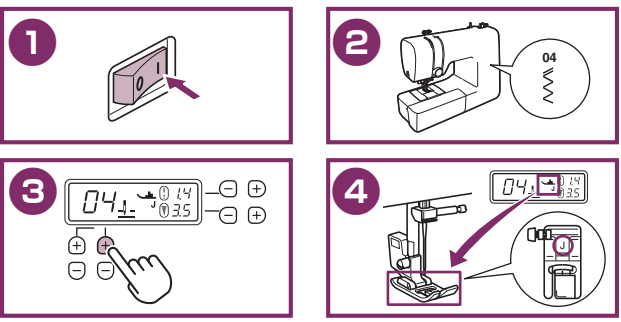

■ Selecting a stitch
Selección de una puntada
Sélection d'un point
Seleção de um ponto

Example:
 Ejemplo:
 Exemple:
 Exemplo:



Depending on the model, the stitch number may be different. You can check the stitch numbers on the machine's body.

Dependiendo del modelo, el número de puntada puede variar. Compruebe los números de puntada en el cuerpo de la máquina.

Le numéro du point peut être différent en fonction du modèle. Vous pouvez vérifier le numéro des points sur la carrosserie de la machine.

Dependendo do modelo, o número de pontos pode ser diferente. Você pode verificar os números de pontos no corpo da máquina.

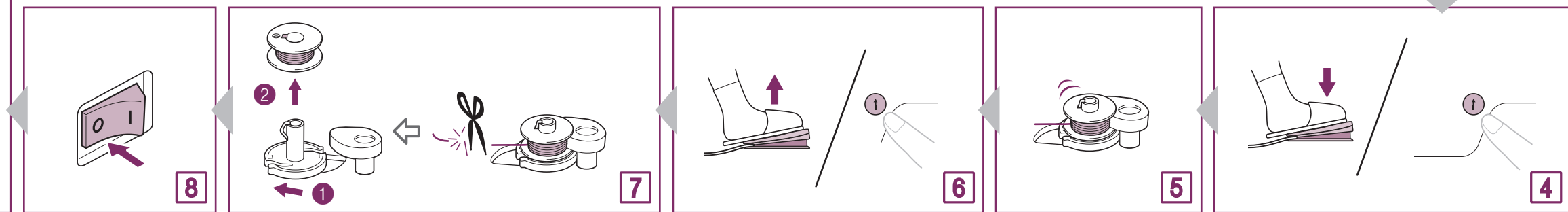
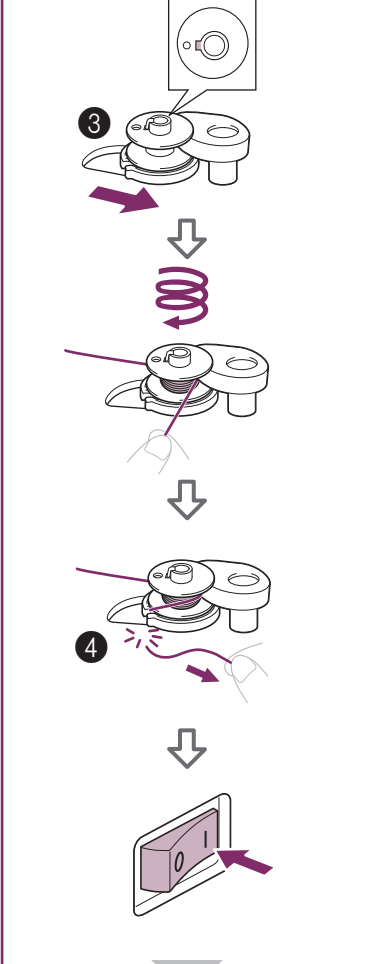
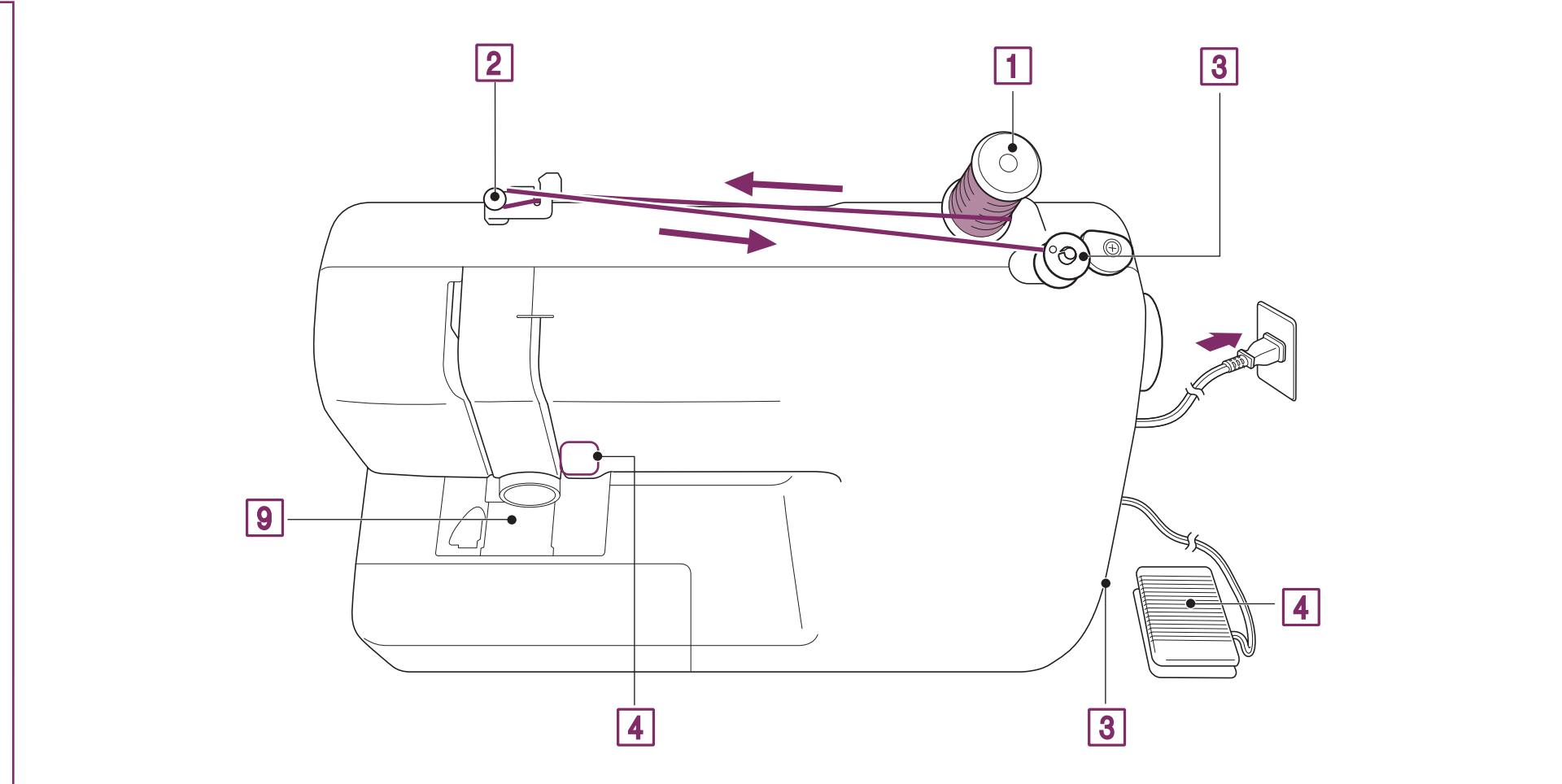
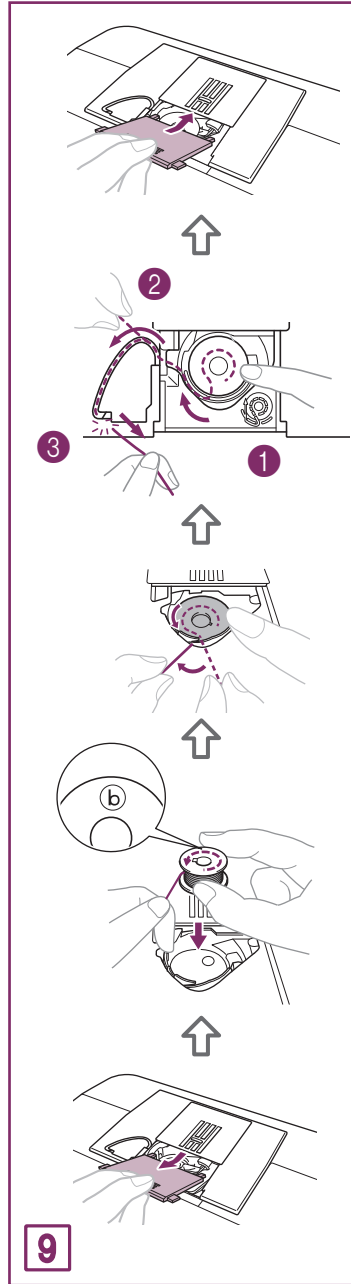
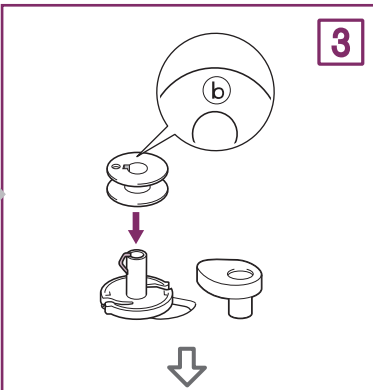
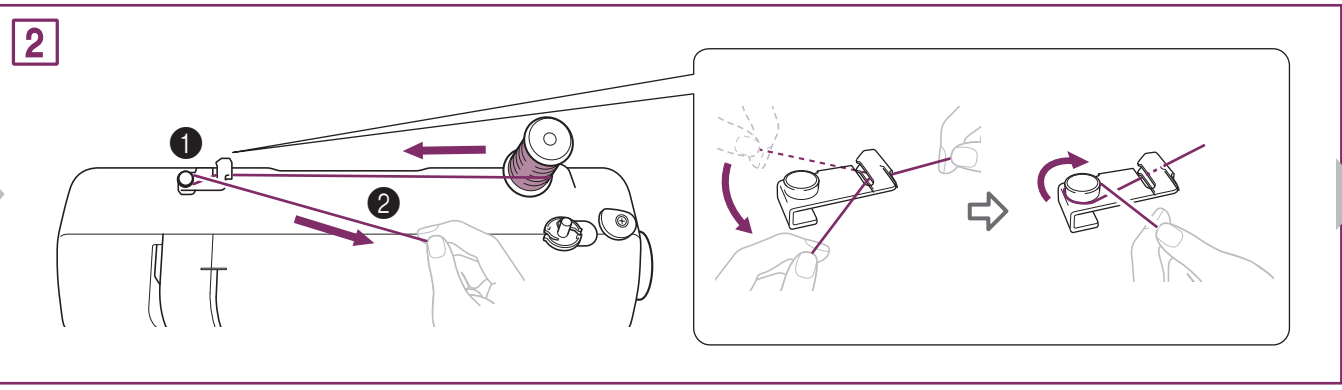
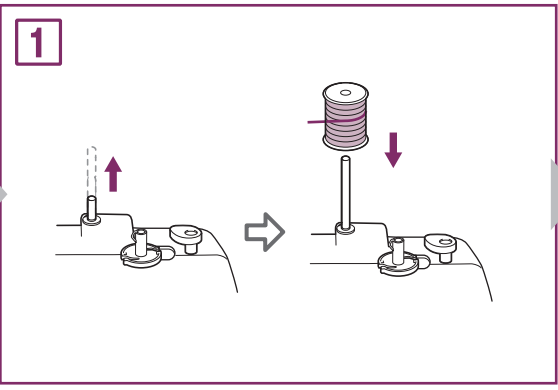
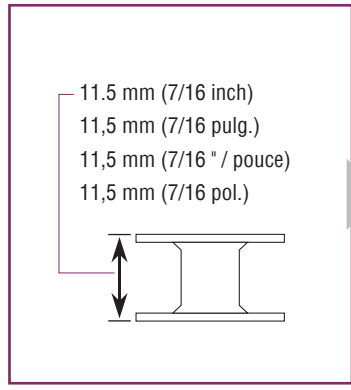

Be sure to first read the "IMPORTANT SAFETY INSTRUCTIONS" in the Operation Manual.
 Refer to the Operation Manual for detailed instruction.

Lea primero las "INSTRUCCIONES DE SEGURIDAD IMPORTANTES" del manual de instrucciones.
 Consulte el manual de instrucciones para obtener información detallada.

Lisez attentivement les « INSTRUCTIONS DE SÉCURITÉ IMPORTANTES » du manuel d'instructions.
 Reportez-vous au manuel d'instructions pour des directives détaillées.

Assegure-se de ler primeiro "INSTRUÇÕES DE SEGURANÇA IMPORTANTES" no Manual de Operações.
 Consulte o Manual de Operações para obter instruções detalhadas.



■ Operation keys and LCD
Teclas de operación y pantalla de LCD
Touche de fonctionnement et écran à cristaux liquides
Teclas de operação e LCD

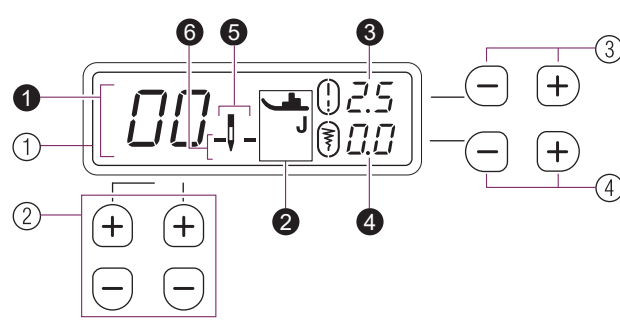

- ① LCD (liquid crystal display)
- ① Number of the selected stitch
 - ② Presser foot to be used
 - ③ Stitch length (mm)
 - ④ Stitch width (mm)
 - ⑤ Single/twin needle mode
 - ⑥ Needle stop position
- ② Stitch selection keys
 ③ Stitch length keys
 ④ Stitch width keys

- ① LCD (pantalla de cristal líquido)
- ① Número de la puntada seleccionada
 - ② Pie prensatela que se va a utilizar
 - ③ Longitud de la puntada (mm)
 - ④ Anchura de la puntada (mm)
 - ⑤ Modo de aguja sencilla/gemela
 - ⑥ Posición de parada de la aguja
- ② Teclas de selección de puntada
 ③ Teclas de longitud de puntada
 ④ Teclas de anchura de puntada

- ① Écran à cristaux liquides
- ① Numéro du point sélectionné
 - ② Pied presseur à utiliser
 - ③ Longueur du point (mm)
 - ④ Largeur du point (mm)
 - ⑤ Mode d'aiguille simple/jumelée
 - ⑥ Position d'arrêt de l'aiguille
- ② Touche de sélection de point
 ③ Touche de longueur du point
 ④ Touche de largeur du point

- ① LCD (tela de cristal líquido)
- ① Número do ponto selecionado
 - ② Calçador a ser utilizado
 - ③ Comprimento do ponto (mm)
 - ④ Largura do ponto (mm)
 - ⑤ Modo de agulha simples/agulha dupla
 - ⑥ Posição de parada da agulha
- ② Teclas de seleção de ponto
 ③ Teclas de comprimento do ponto
 ④ Teclas de largura do ponto



Settings/Functions / Ajustes/Funções /
Réglages/Fonctions / Configurações/Funções

To change the settings: Holding down the key (①-⑦) specified for each function, press the main power switch to turn on the machine.
* Refer to the Operation Manual for details.

Para cambiar los ajustes: Mantenga pulsada la tecla (①-⑦) especificada para cada función, pulse el interruptor de la alimentación para encender la máquina.
* Para más información, consulte el manual de instrucciones.

Pour modifier les réglages: Maintenir les touches enfoncées (①-⑦) spécifiées pour chaque fonction, appuyer sur l' interrupteur d' alimentation principal pour mettre la machine sous tension.
* Se reporter au Manuel d' instructions pour plus de détails.

Para alterar as configurações: Segurando a tecla (①-⑦) especificada para cada função, pressione o interruptor Liga/Desliga para ligar a máquina.
* Consulte o Manual de Operação para obter detalhes.

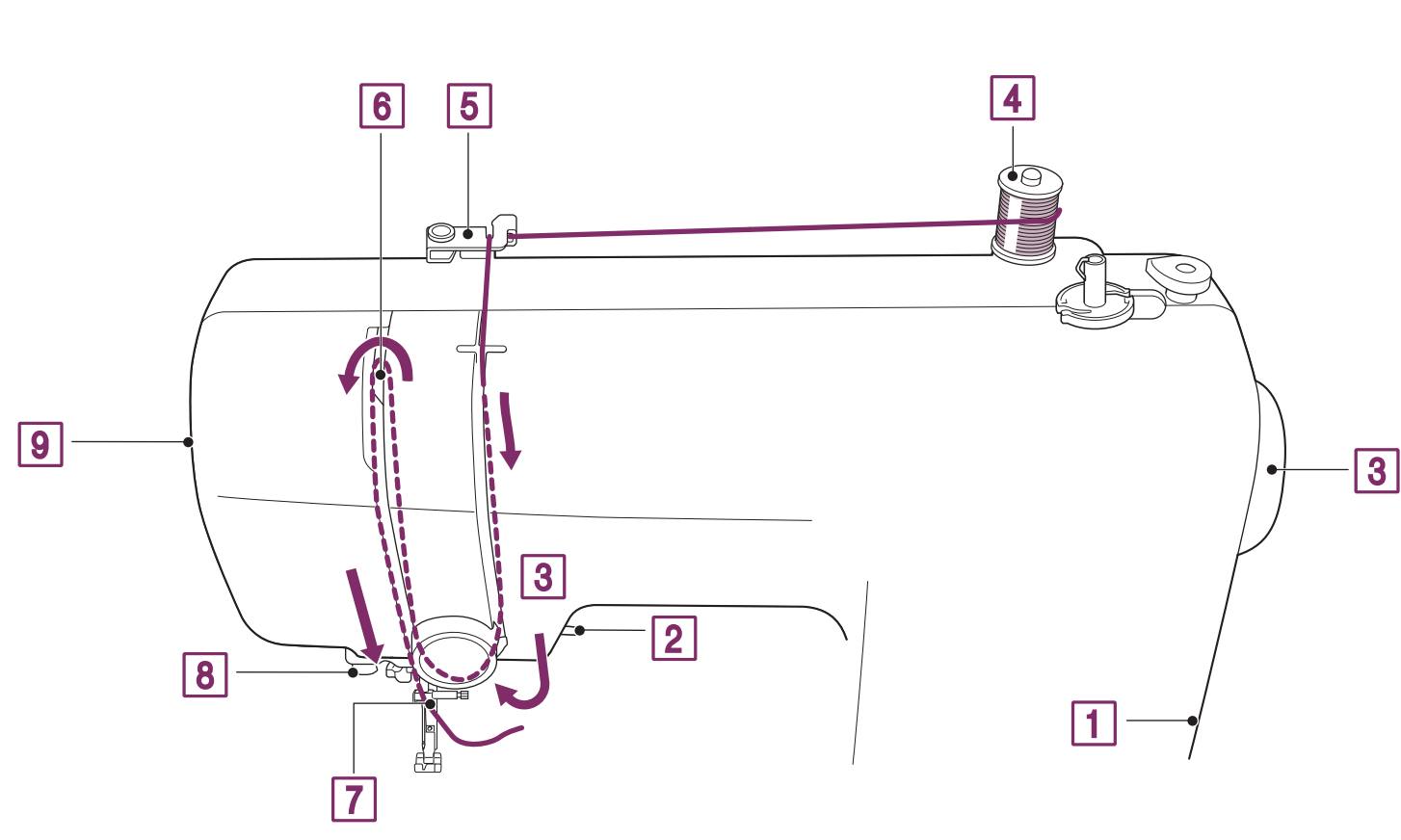
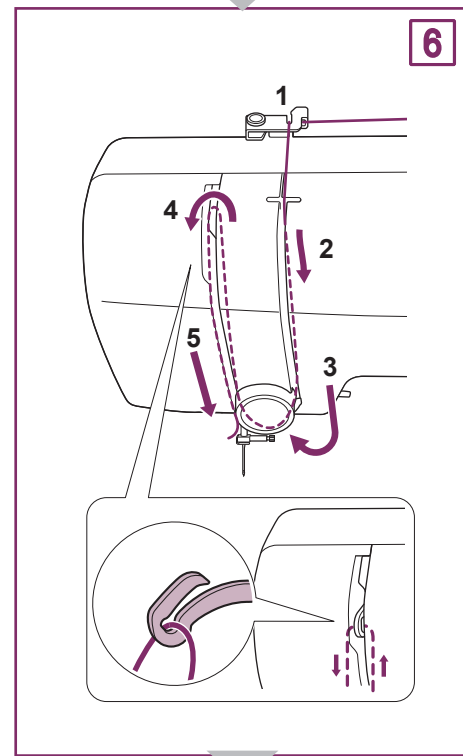
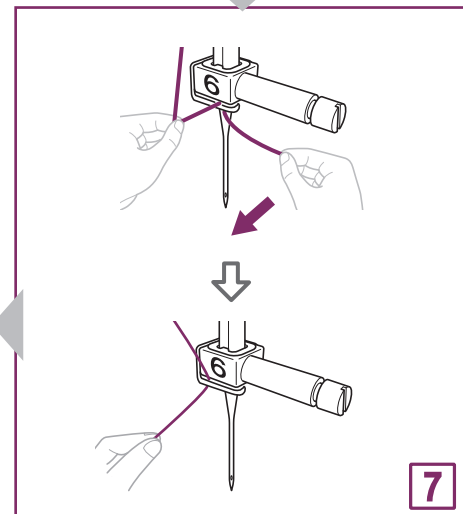
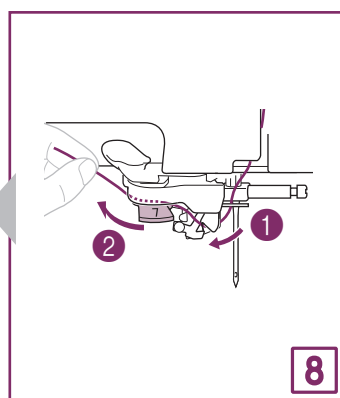
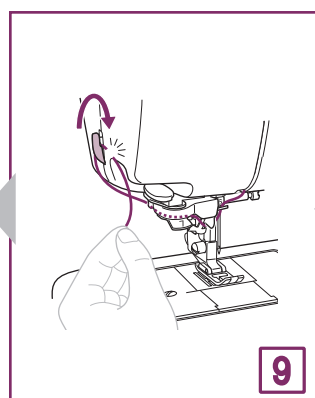
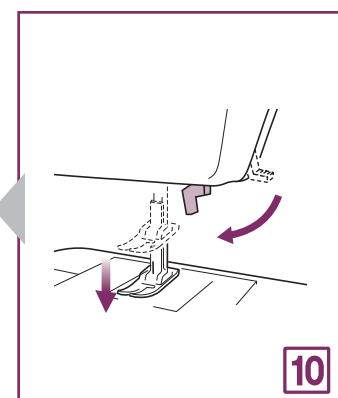
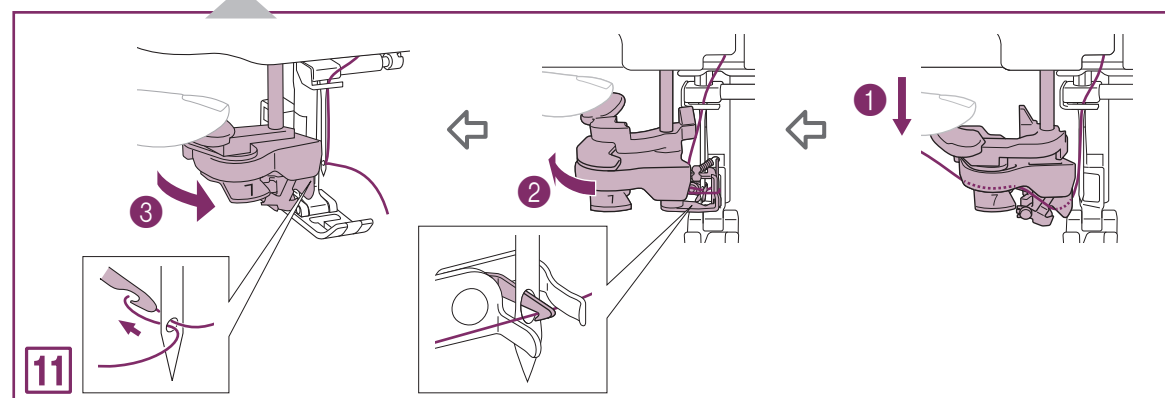
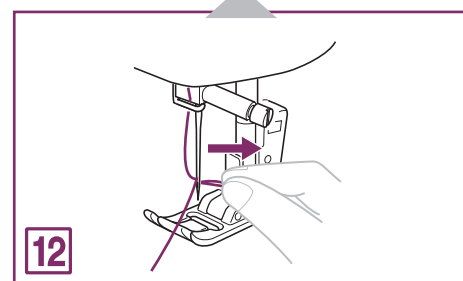
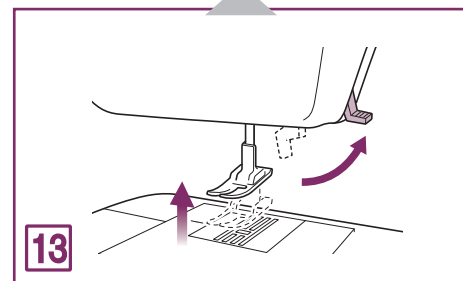
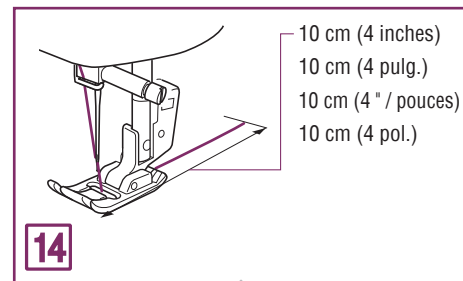
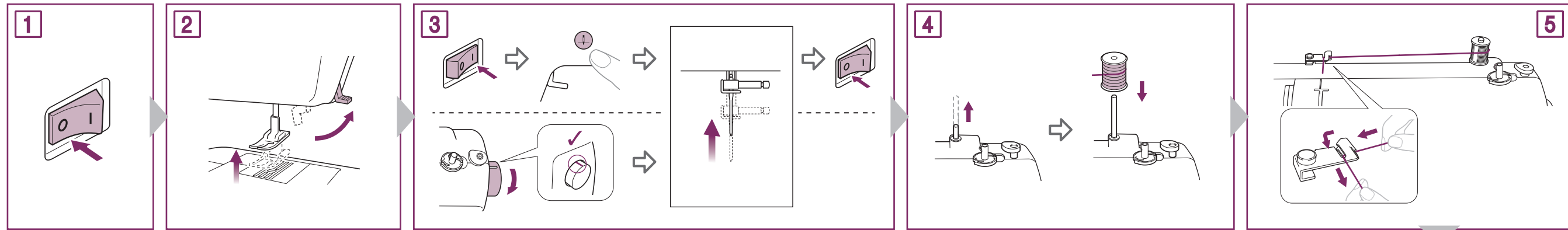
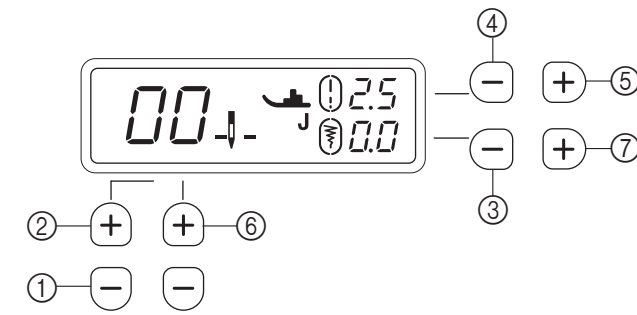

No. / N° N° / N°	Function / Función / Fonction / Função	
①	Needle stop position (lowered/raised) Posición de parada de la aguja (bajada/subida) Position d'arrêt de l'aiguille (abaissée/relevée) Posição de parada da agulha (baixada/elevada)	↓- / ↓
②	Initial needle position (left/middle (center)) Posición de aguja inicial (izquierda/medio (centro)) Position de l'aiguille initiale (gauche/milieu (centre)) Posição inicial da agulha (esquerda/meio (centro))	
③★	Operation beep (on/off) Pitido de funcionamento (encendido/apagado) Bip de fonctionnement (activé/désactivé) Bipe de operação (ligado/desligado)	
④	Maximum sewing speed (○standard/●slower) Velocidad de costura máxima (○estándar/●más lenta) Vitesse maximale de couture (○standard/●plus réduite) Velocidade máxima de costura (○padrão/●lenta)	○ / ●
⑤	Automatic reverse/reinforcement stitching (○off/●on) Puntada en reversa/remate automática (○apagado/●encendido) Couture de points inverses/de renfort automatique (○désactivée/●activée) Costura automática de pontos de retrocesso/reforço (○desligada/●ligada)	○ / ●
⑥	Needle mode (single/twin) Modo de aguja (sencilla/gemela) Mode d'aiguille (simple/jumelée) Modo de agulha (simples/dupla)	↓- / ↓-
⑦★	Stitch adjustment Ajuste de puntada Réglage du point Ajuste de ponto	

★ : Only for some models. / ★ : Solo para algunos modelos. /
★ : Uniquement pour certains modèles. / ★ : Para alguns modelos apenas.